

- Dual Outputs:
+3.3V/2.5V
+3.3V/1.5V
+3.3V/1.8V
- Adjustable Output Voltage
- Remote Sense (both outputs)
- Standby Function
- Over-Temperature Protection
- Soft-Start
- Internal Sequencing
- 23-pin Excalibur™ Package

The PT6930 is a new series of 25W dual output ISRs designed to power the latest generation DSP chips. Both output voltages are independently adjustable with external resistors. In addition, the second output voltage of the PT6931 can be selected for either 2.5V or 1.8V to accommodate the next generation of DSP chips. The internal power sequencing of both outputs meet the requirements of TI's 'C6000 series DSPs.

Patent pending on package assembly

Standard Application

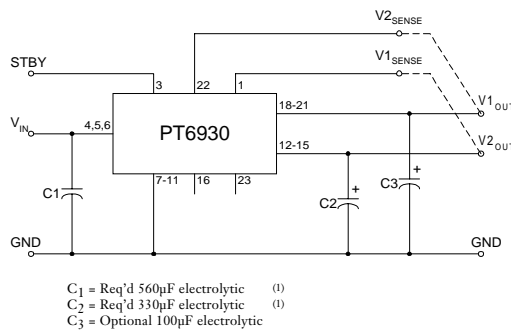

Pin-Out Information

Pin	Function	Pin	Function
1	V ₁ Remote Sense	13	V ₁ OUT
2	Do Not Connect	14	V ₁ OUT
3	STBY	15	V ₁ OUT
4	V _{in}	16	V ₁ Adjust
5	V _{in}	17	Do Not Connect
6	V _{in}	18	V ₂ OUT
7	GND	19	V ₂ OUT
8	GND	20	V ₂ OUT
9	GND	21	V ₂ OUT
10	GND	22	V ₂ Remote Sense
11	GND	23	V ₂ Adjust*
12	V ₁ OUT		

*Note: V₁OUT and V₂OUT are adjustable, and can be pin-strapped to produce at least one alternative common bus voltage. Consult the factory for more information.

Ordering Information

- PT6931□ = +3.3 Volts
+2.5/1.8 Volts
- PT6932□ = +3.3 Volts
+1.5/1.2 Volts
- PT6933□ = +3.3 Volts
+1.8/1.2 Volts

PT Series Suffix (PT1234X)

Case/Pin Configuration	
Vertical Through-Hole	N
Horizontal Through-Hole	A
Horizontal Surface Mount	C

(For dimensions and PC board layout, see Package Styles 1320 and 1330.)

Specifications

Characteristics (T _a = 25°C unless noted)	Symbols	Conditions	PT6930 SERIES			Units	
			Min	Typ	Max		
Output Current	I _o	T _a = +60°C, 200 LFM, pkg N	V ₁ = 3.3V	0.1 (2)	—	5.5 (3)	A
			V ₂ = 2.5V	0	—	2.2 (3)	
			V ₂ = 1.8V	0	—	1.75 (3)	
		T _a = +25°C, natural convection	V ₂ = 1.5V	0	—	1.45 (3)	
			V ₂ = 1.2V	0	—	1.2 (3)	
			V ₁ = 3.3V	0.1	—	6.0	
V ₂ = 2.5V	0	—	2.2				
V ₂ = 1.8V	0	—	1.75				
Input Voltage Range	V _{in}	0.1A ≤ I _o ≤ I _{max}	4.5	—	5.5	V	
Output Voltage Tolerance	ΔV _o	V _{in} = +5V, I _o = I _{max} , both outputs 0°C ≤ T _a ≤ +65°C	V _o -0.1	—	V _o +0.1	V	
Line Regulation	Reg _{line}	4.5V ≤ V _{in} ≤ 5.5V, I _o = I _{max}	V ₁ = 3.3V V ₂ = 2.5V	— —	±7 ±7	±17 ±13	V
Load Regulation	Reg _{load}	V _{in} = +5V, 0.1 ≤ I _o ≤ I _{max}	V ₁ = 3.3V V ₂ = 2.5V	— —	±17 ±4	±33 ±10	mV
V _o Ripple/Noise	V _n	V _{in} = +5V, I _o = I _{max}	V ₁ = 3.3V V ₂ = 2.5V	— —	50 25	— —	mV
Transient Response with C ₂ = 330µF	t _{tr}	I _o step between 0.5I _{max} and I _{max} V _o over/undershoot	V ₁ = 3.3V	—	25	—	µSec
	V _{os}		V ₁ = 3.3V V ₂ = 2.5V	— —	60 60	— —	mV
Efficiency	η	V _{in} = +5V, I _o = 4A total	—	75	—	—	%
Switching Frequency	f _o	4.5V ≤ V _{in} ≤ 5.5V 0.1A ≤ I _o ≤ I _{max}	475	600	725	—	kHz
Absolute Maximum Operating Temperature Range	T _a	—	-40 (4)	—	+85 (5)	—	°C
Storage Temperature	T _s	—	-40	—	+125	—	°C
Weight	—	Vertical/Horizontal	—	29	—	—	grams

- Notes: (1) The PT6930 series requires a 560µF electrolytic capacitor on the input and a 330µF electrolytic capacitor on the output for proper operation in all applications.
 (2) I_omin current of 0.1A can be divided between both outputs; V₁, or V₂. The ISR will operate down to no-load with reduced specifications.
 (3) I_omax listed for each output assumes the maximum current drawn simultaneously on both outputs. Consult the factory for the absolute maximum.
 (4) For operating temperatures below 0°C, use tantalum type capacitors on both the input and output.
 (5) See Safe Operating Area curves for appropriate derating.

PT6931, $V_{2out} = 2.5V$, $I_{2out} = 2.2A$ (See Note A)

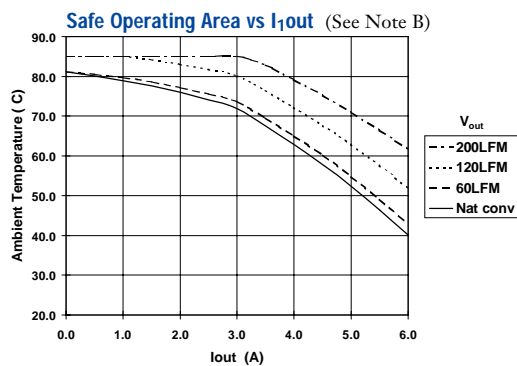
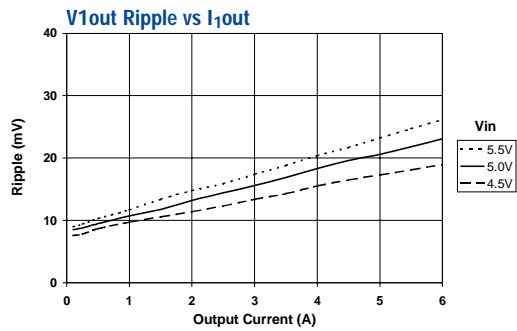
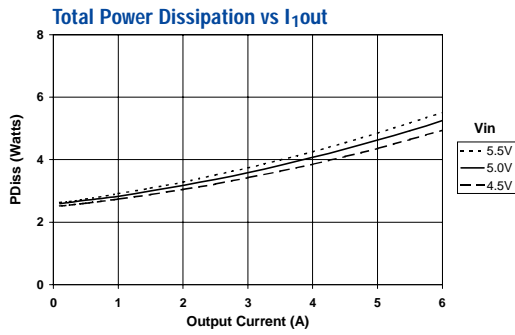
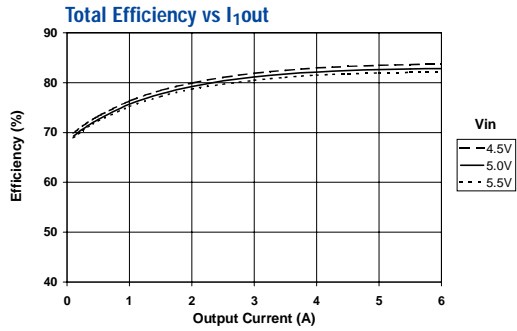

Note A: All characteristic data in the above graphs has been developed from actual products tested at 25°C. This data is considered typical data for the ISR.

Note B: SOA curves represent operating conditions at which internal components are at or below the manufacturer's maximum rated operating temperatures.

Adjusting the Output Voltage of the PT6920 and PT6930 Dual Output Voltage ISRs

Each output voltage from the PT6920 and PT6930 series of ISRs can be independently adjusted higher or lower than the factory trimmed pre-set voltage. V_1 (the voltage at V_{1out}), or V_2 (the voltage at V_{2out}) may each be adjusted either up or down using a single external resistor². Table 1 gives the adjustment range for both V_1 and V_2 for each model in the series as $V_a(\min)$ and $V_a(\max)$. Note that V_2 must always be lower than V_1 ³.

V_1 Adjust Up: To increase the output, add a resistor R4 between pin 16 (V_1 Adjust) and pins 7-11 (GND)².

V_1 Adjust Down: Add a resistor (R3), between pin 16 (V_1 Adjust) and pin 1 (V_1 Remote Sense)².

V_2 Adjust Up: Add a resistor R2 between pin 23 (V_2 Adjust) and pins 7-11 (GND)².

V_2 Adjust Down: Add a resistor (R1) between pin 23 (V_2 Adjust) and pin 22 (V_2 Remote Sense)².

Refer to Figure 1 and Table 2 for both the placement and value of the required resistor.

Notes:

1. The output voltages, V_{1out} and V_{2out} , may be adjusted independently.
2. Use only a single 1% resistor in either the (R3) or R4 location to adjust V_1 , and in the (R1) or R2 location to adjust V_2 . Place the resistor as close to the ISR as possible.
3. V_2 must always be at least 0.2V lower than V_1 .
4. V_2 on both the PT6921 and PT6931 models may be adjusted from 2.5V to 1.8V by simply connecting pin 22 (V_2 Remote Sense) to pin 23 (V_2 Adjust). For more details, consult the data sheet.

5. If V_1 is increased above 3.3V, the minimum input voltage to the ISR must also be increased. The minimum required input voltage must be $(V_1 + 1.2)V$ or 4.5V, whichever is greater. Do not exceed 5.5V
6. Never connect capacitors to either the V_1 Adjust or V_2 Adjust pins. Any capacitance added to these control pins will affect the stability of the respective regulated output.
7. Adjusting either voltage (V_1 or V_2) may increase the power dissipation in the regulator, and correspondingly change the maximum current available at either output. Consult the factory for application assistance.

The adjust up and adjust down resistor values can also be calculated using the following formulas. Be sure to select the correct formula parameter from Table 1 for the output and model being adjusted.

$$(R1) \text{ or } (R3) = \frac{R_o(V_a - V_r)}{V_o - V_a} - R_s \quad k\Omega$$

$$R2 \text{ or } R4 = \frac{V_r \cdot R_o}{V_a - V_o} - R_s \quad k\Omega$$

Where: V_o = Original output voltage, (V_1 or V_2)
 V_a = Adjusted output voltage
 V_r = The reference voltage from Table 1
 R_o = The resistance value from Table 1
 R_s = The series resistance from Table 1

Table 1

PT6920 ADJUSTMENT RANGE AND FORMULA PARAMETERS				
Output Bus	V_1 out	V_2 out		
Series Pt #				
Standard Case	PT6921/22	PT6921	PT6922	
Excalibur Case	PT6931/32	PT6931	PT6932	PT6933
Adj. Resistor	(R3)/R4	(R1)/R2	(R1)/R2	(R1)/R2
$V_o(\text{nom})$	3.3V	2.5V	1.5V	1.8V
$V_a(\min)$	2.3V	1.8V	1.2V	1.2V
$V_a(\max)$	3.6V	3.0V	3.0V	3.0V
V_r	1.02V	1.0V	1.0V	1.0V
R_o (k Ω)	12.1	10.0	9.76	10.0
R_s (k Ω)	12.1	11.5	6.49	3.32

Figure 1

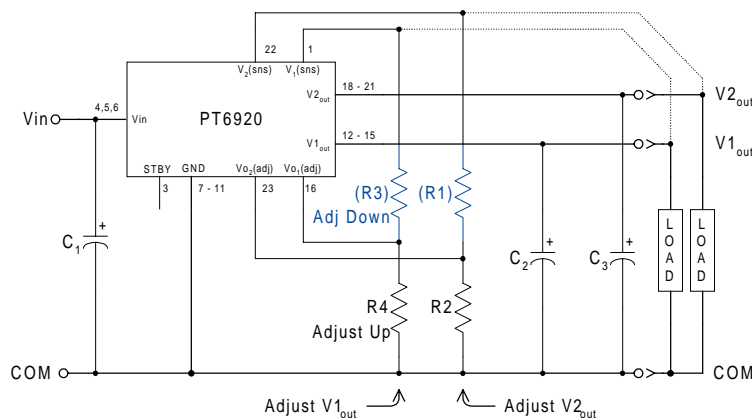

PT6920/PT6930 Series

Table 2

PT6920/PT6930 ADJUSTMENT RESISTOR VALUES

Output Bus	V _{1out}	V _{2out}		
Series Pt#				
Standard Case	PT6921/6922	PT6921	PT6922	
Excalibur Case	PT6931/6932	PT6931	PT6932	PT6933
Adj Resistor	(R3)/R4	(R1)/R2	(R1)/R2	(R1)/R2
V _o (nom)	3.3Vdc	2.5Vdc	1.5Vdc	1.8Vdc
V _a (req'd)				
1.2		(0.0)kΩ	(0.0)kΩ	
1.25		(3.3)kΩ	(1.2)kΩ	
1.3		(8.2)kΩ	(2.7)kΩ	
1.35		(16.3)kΩ	(4.5)kΩ	
1.4		(32.6)kΩ	(6.7)kΩ	
1.45		(81.4)kΩ	(9.5)kΩ	
1.5			(13.3)kΩ	
1.55		189.0kΩ	(18.7)kΩ	
1.6		91.1kΩ	(26.7)kΩ	
1.65		58.6kΩ	(40.0)kΩ	
1.7		42.3kΩ	(66.7)kΩ	
1.75		32.6kΩ	(147.0)kΩ	
1.8		(0.0)kΩ	26.0kΩ	
1.85		(1.6)kΩ	21.4kΩ	197.0kΩ
1.9		(3.5)kΩ	17.9kΩ	96.7kΩ
1.95		(5.8)kΩ	15.2kΩ	63.3kΩ
2.0		(8.5)kΩ	13.0kΩ	46.7kΩ
2.05		(11.8)kΩ	11.3kΩ	36.7kΩ
2.1		(16.0)kΩ	9.8kΩ	30.0kΩ
2.15		(21.4)kΩ	8.5kΩ	25.3kΩ
2.2		(28.5)kΩ	7.5kΩ	21.7kΩ
2.25		(38.5)kΩ	6.5kΩ	18.9kΩ
2.3	(3.4)kΩ	(53.5)kΩ	5.7kΩ	16.7kΩ
2.35	(4.8)kΩ	(78.5)kΩ	5.0kΩ	14.9kΩ
2.4	(6.5)kΩ	(129.0)kΩ	4.4kΩ	13.3kΩ
2.45	(8.3)kΩ	(279.0)kΩ	3.8kΩ	12.1kΩ
2.5	(10.3)kΩ		3.3kΩ	11.0kΩ
2.55	(12.6)kΩ	189.0kΩ	2.8kΩ	10.0kΩ
2.6	(15.2)kΩ	88.5kΩ	2.4kΩ	9.2kΩ
2.65	(18.2)kΩ	55.2kΩ	2.0kΩ	8.4kΩ
2.7	(21.8)kΩ See Note 3	38.5kΩ	1.6kΩ	7.8kΩ
2.75	(26.0)kΩ	28.5kΩ	1.3kΩ	7.2kΩ
2.8	(31.0)kΩ	21.8kΩ	1.0kΩ	6.7kΩ
2.85	(37.1)kΩ	17.1kΩ	0.7kΩ	6.2kΩ
2.9	(44.8)kΩ	13.5kΩ	0.5kΩ	5.8kΩ
2.95	(54.6)kΩ	10.7kΩ	0.2kΩ	5.4kΩ
3.0	(67.8)kΩ	8.5kΩ	0.0kΩ	5.0kΩ
3.05	(86.2)kΩ			
3.1	(114.0)kΩ			
3.15	(160.0)kΩ			
3.2	(252.0)kΩ			
3.25	(528.0)kΩ			
3.3				
3.4	111.0kΩ See Note 5			
3.5	49.6kΩ			
3.6	29.0kΩ			

R1/R3 = (Blue) R2/R4 = Black

Using the Standby Function on the PT6920 and PT6930 Dual Output Voltage Converters

Both output voltages of the 23-pin PT6920/6930 dual output converter may be disabled using the regulator's standby function. This function may be used in applications that require power-up/shutdown sequencing, or wherever there is a requirement to control the output voltage On/Off status with external circuitry.

The standby function is provided by the *STBY** control, pin 3. If pin 3 is left open-circuit the regulator operates normally, and provides a regulated output at both $V_{1,out}$ (pins 12–15) and $V_{2,out}$ (pins 18–21) whenever a valid supply voltage is applied to V_{in} (pins 4, 5, & 6) with respect to GND (pins 7-11). If a low voltage² is then applied to pin-3 both regulator outputs will be simultaneously disabled and the input current drawn by the ISR will typically drop to less than 30mA (50mA max). The standby control may also be used to hold-off both regulator outputs during the period that input power is applied.

The standby pin is ideally controlled using an open-collector (or open-drain) discrete transistor (See Figure 1). It may also be driven directly from a dedicated TTL³ compatible gate. Table 1 provides details of the threshold requirements.

Table 1 Inhibit Control Thresholds^{2,3}

Parameter	Min	Max
Enable (V _{IH})	1.8V	V _{in}
Disable (V _{IL})	-0.1V	0.8V

Notes:

1. The Standby/Inhibit control logic is similar for all Power Trends' modules, but the flexibility and threshold tolerances will be different. For specific information on this function for other regulator models, consult the applicable application note.
2. The Standby control pin is ideally controlled using an open-collector (or open-drain) discrete transistor and requires no external pull-up resistor. To disable the regulator output, the control pin must be pulled to less than 0.8Vdc with a low-level 0.5mA sink to ground.
3. The Standby input on the PT6920/6930 series may be driven by a differential output device, making it directly compatible with TTL logic. The control input has an internal pull-up to the input voltage V_{in} . A voltage of 1.8V or greater ensures that the regulator is enabled. *Do not* use devices that can drive the Standby control input above 5.5V or V_{in} .

Figure 1

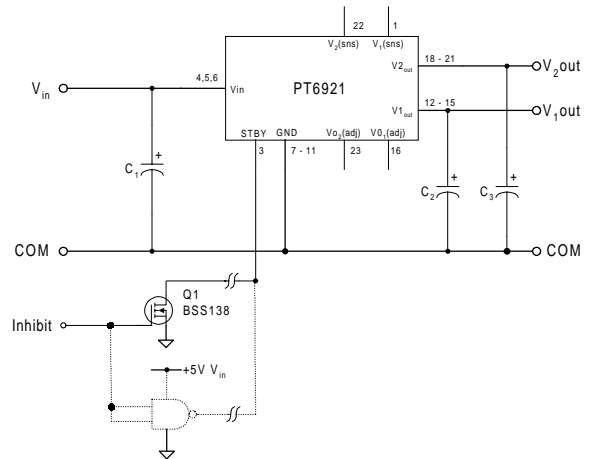

Turn-On Time: Turning Q_1 in Figure 1 off removes the low-voltage signal at pin 3 and enables both outputs from the PT6920/6930 regulator. Following a delay of about 5–10ms, $V_{1,out}$ and $V_{2,out}$ rise together until the lower voltage, $V_{2,out}$, reaches its set output. $V_{1,out}$ then continues to rise until both outputs reach full regulation voltage. The total power-up time is less than 15ms, and is relatively independent of load, temperature, and output capacitance. Figure 2 shows waveforms of the input current I_{in} , and output voltages $V_{1,out}$ and $V_{2,out}$, for a PT6921 (3.3V/2.5V). The turn-off of Q_1 corresponds to $t = 0$ secs. The waveforms were measured with a 5Vdc input voltage, and with resistive loads of 5.5A and 2.2A at the $V_{1,out}$ and $V_{2,out}$ outputs respectively.

Figure 2

